



# GLOBE VALVES

**A**  
**14**

**G.M. Gun Metal**  
**S.S. Stainless Steel**  
**M.B. Manganese Bronze**

**C.I. Cast Iron**  
**C.S. Cast Steel**

## INDEX OF ILLUSTRATED VALVES & EQUIVALENTS IN VARIOUS MATERIALS

NEEDLE TYPE ANGLE PATTERN GLOBE VALVES	End Connections	Body & Bonnet	Screwed Bonnet	Bolted Bonnet	Seat Material	Disc	Spindle	Inside Screw	Outside Screw	Rating		
										Working pressure	Max Temp	Working pressure at max temp.
										kPa psi	°C °F	kPa psi
2338 GUN METAL	Screwed B.S.P.T Female	GM	✓		SS	SS	MB	✓		3450 500	260 500	1725 250

SIZE (MM)	15
DIMENSIONS (MM)	
A	36
B	127
Ø C	71

Globe valve angle pattern, needle design, screwed bonnet, inside screwed spindle, renewable stainless steel seat and disc, manganese bronze spindle.

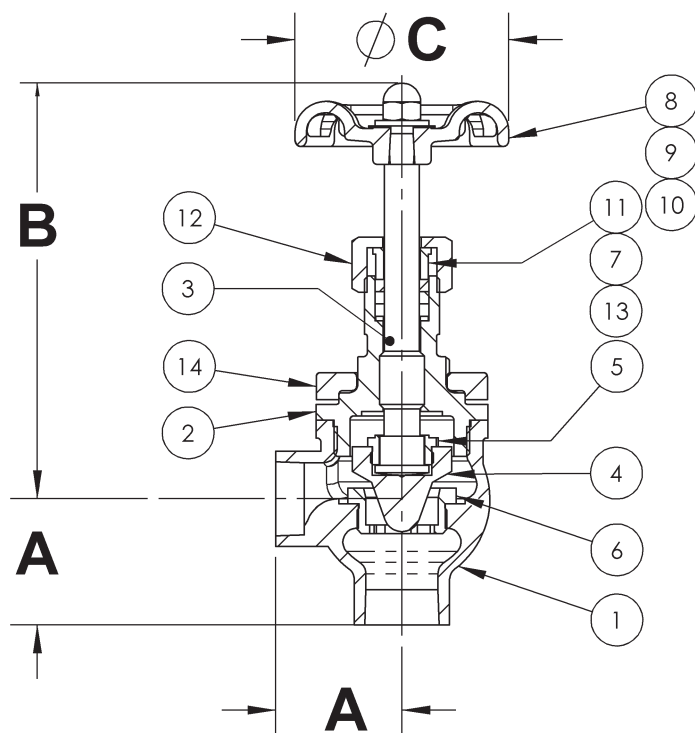

### PARTS LIST.

1. Body
2. Bonnet
3. Spindle
4. Valve
5. Nut
6. Seat
7. Gland Nut
8. Handwheel
9. Nut
10. Nameplate
11. Washer
12. Gland Nut
13. Packing
14. Bonnet Locker