

GLOBE VALVES



G.M. Gun Metal
S.S. Stainless Steel
M.B. Manganese Bronze

C.I. Cast Iron
C.S. Cast Steel

A
5

INDEX OF ILLUSTRATED VALVES & EQUIVALENTS IN VARIOUS MATERIALS



NEEDLE TYPE STRAIGHT PATTERN GLOBE VALVES	End Connections	Body & Bonnet	Union Bonnet	Bolted Bonnet	Seat Material	Disc	Spindle	Inside Screw	Outside Screw	Rating		
										Working pressure	Max Temp	Working pressure at max temp.
										kPa psi	°C °F	kPa psi
1438 GUN METAL	Screwed B.S.P.T	GM	✓		P.T.F.E or Integral	Glass Filled P.T.F.E	SS	✓		5000 725	190 374	3180 461
1438A GUN METAL	Screwed N.P.T	GM	✓		P.T.F.E or Integral	Glass Filled P.T.F.E	SS	✓		5000 725	190 374	3180 461
1438F GUN METAL	Stub Ends	GM	✓		P.T.F.E or Integral	Glass Filled P.T.F.E	SS	✓		5000 725	190 374	3180 461
1498 STAINLESS STEEL	Screwed B.S.P.T	SS	✓		P.T.F.E or Integral	Glass Filled P.T.F.E	SS	✓		4960 719	190 374	3620 525

SIZE (MM)	8-10	15	20	25	32	40	50
DIMENSIONS (MM)							
A	67	67	83	95	108	117	154
B	140	140	149	178	181	197	222
Ø C	60	60	60	76	76	102	121

Globe valve, straight pattern, union bonnet, inside screwed spindle, integral seat, PTFE soft seated replaceable valve member, screwed ends

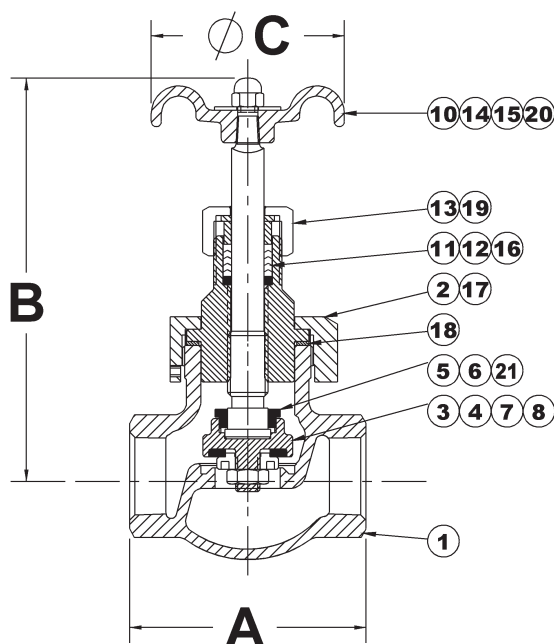

PARTS LIST.

- | | |
|------------------|------------------|
| 1. Body | 12. Bonnet |
| 2. Union Nut | 13. Gland Nut |
| 3. Disc Holder | 14. Hand Wheel |
| 4. Disc | 15. Hex Nut |
| 5. Nut | 16. Gland Washer |
| 6. Spindle | 17. Grub Screw |
| 7. Retaining Nut | 18. Gasket |
| 8. Lock Nut | 19. Gland |
| 10. Nameplate | 20. Washer |
| 11. Packing | 21. Tab Washer |

Mack Valves Head Office
30 Burgess Road
BAYSWATER, VIC 3153
Tel: (03) 9737 5200
Fax: (03) 9720 1344
Email: enquiries@mackvalves.com.au

Mack Valves NSW Office
Unit 9/9-11 Abel Street
Penrith NSW 2750
Tel: (02) 4722 6033
Fax: (02) 4722 6144
Email: enquiries.nsw@mackvalves.com.au

Mack Valves SA Office
204 Prospect Road
Prospect SA 5082
Tel: (08) 8269 6477
Fax: (08) 8344 5934
Email: enquiries.sa@mackvalves.com.au