

CHECK VALVES



G.M. Gun Metal
S.S. Stainless Steel
M.B. Manganese Bronze

C.I. Cast Iron
C.S. Cast Steel

B
19

INDEX OF ILLUSTRATED VALVES & EQUIVALENTS IN VARIOUS MATERIALS

CHECK VALVES ANGLE CONTROLLABLE LIFT	End Connections	Body & Bonnet	Screwed Bonnet	Bolted Bonnet	Seat Material	Disc	Type	Bronze Liner & Piston	Rating		
									Working pressure	Max Temp	Working pressure at max temp.
									kPa psi	°C °F	kPa psi
4948 GUN METAL	Screwed B.S.P.T	GM		✓	SS	SS	SDNR		3450 500	260 500	1725 250
4998 STAINLESS STEEL	Screwed B.S.P.T	SS		✓	SS	SS	SDNR		4960 720	538 1000	2520 365

SIZE (MM)	15	20	25	32	40	50
DIMENSIONS (MM)						
A	37	45	51	57	64	79
B	133	133	140	159	197	215
∅ C	70	70	90	108	102	155

Controllable Lift Check valve, angle pattern body, screwed bonnet, inside screwed spindle, renewable seat and disc, screwed ends.

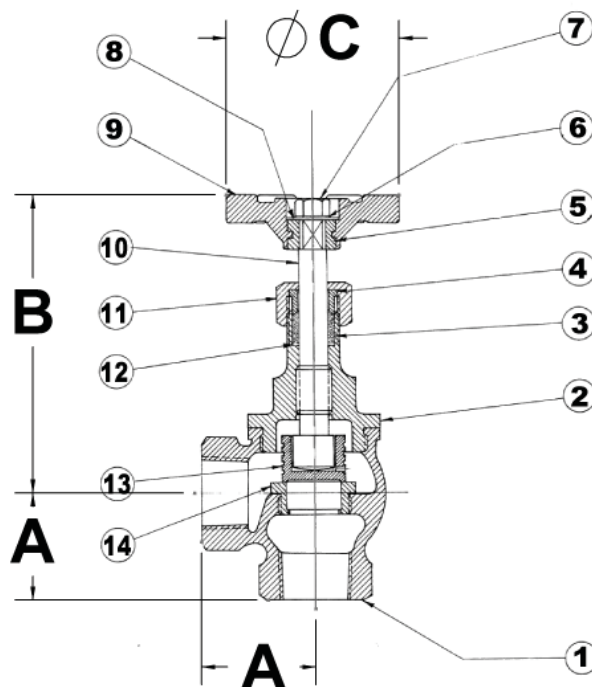

PARTS LIST.

1. Body
2. Bonnet
3. Packing
4. Gland
5. Insert
6. Washer
7. Nut
8. Nameplate
9. Handwheel
10. Spindle
11. Gland Nut
12. Washer
13. Piston
14. Seat