



CRYOGENIC VALVES

0
4

G.M. Gun Metal
S.S. Stainless Steel
M.B. Manganese Bronze

FOR GAS
SERVICE
OXYGEN APPROVED

INDEX OF ILLUSTRATED VALVES & EQUIVALENTS IN VARIOUS MATERIALS

MANUFACTURED IN MATERIALS TO MEET INTERNATIONAL STANDARDS



CRYOGENIC BOLTED BONNET GLOBE VALVES	End Connections	Body & Bonnet	Screwed Bonnet	Bolted Bonnet	Seat Material	Disc	Packing	Inside Screw	Outside Screw	Rating	
										Pressure kPa psi	Temp °C
12808WCR STAINLESS STEEL	Socket Weld	SS		✓	Integral	PTFE Carbon Filled	Graphite		✓	5000 725	-196°C to +190°C
12808ACR STAINLESS STEEL	Screwed N.P.T	SS		✓	Integral	PTFE Carbon Filled	Graphite		✓	5000 725	-196°C to +190°C
12898WCR STAINLESS STEEL	Socket Weld	SS		✓	Integral	SS	Graphite		✓	5000 725	-196°C to +250°C
12898ACR STAINLESS STEEL	Screwed N.P.T	SS		✓	Integral	SS	Graphite		✓	5000 725	-196°C to +250°C

SIZE (MM)	15	25	40	50
DIMENSIONS (MM)				
A	68	92	121	146
B	355	447	492	510
C	60	76	102	121
WEIGHT (KGS)	2.4	4.1	7.6	12.6
KVS - VALUE	3.8	8.8	21	35
CV - VALUE	4.4	10.2	24	40

Stainless steel body and bonnet, with PCTFE disc or hard valve/seat arrangement. Graphite Packing as standard.

FIRESAFE THREAD TO EN10497

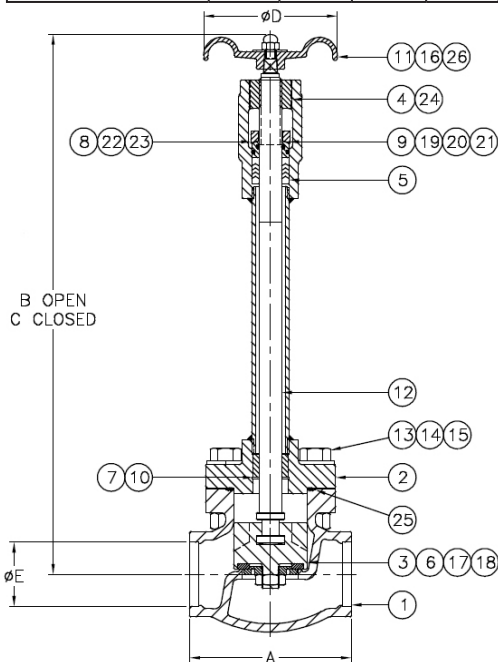

ALSO AVAILABLE IN STUB ENDS, SOCKET WELD FOR PIPE AND METRIC TUBE

Parts List.

- | | |
|---------------------|-------------------|
| 1. Body | 14. Hex Nut |
| 2. Bonnet Assembly | 15. Spring Washer |
| 3. Disc Holder | 16. Dome Nut |
| 4. Threaded Bushing | 17. Disc Nut |
| 5. Packing | 18. Nut |
| 6. Disc | 19. Hex Bolt |
| 7. Circlip | 20. Hex Nut |
| 8. Packing Ring | 21. Spring Washer |
| 9. Gland | 22. 'O' Ring |
| 10. Lower Bushing | 23. 'O' Ring |
| 11. Handwheel | 24. Grub Screw |
| 12. Spindle | 25. Bonnet Gasket |
| 13. Hex Bolt | 26. Name Plate |

Mack Valves Head Office
30 Burgess Road
BAYSWATER, VIC 3153
Tel: (03) 9737 5200
Fax: (03) 9720 1344
Email: enquiries@mackvalves.com.au

Mack Valves NSW Office
Unit 9/9-11 Abel Street
Penrith NSW 2750
Tel: (02) 4722 6033
Fax: (02) 4722 6144
Email: enquiries.nsw@mackvalves.com.au

Mack Valves SA/WA Office
204 Prospect Road
Prospect SA 5082
Tel: (08) 8269 6477
Fax: (08) 8344 5934
Email: enquiries.sa@mackvalves.com.au